

THE



FUEL PUMP

Type

AUF 400

(SPECIFICATION RANGE: AUF 400 TO AUF 499)

DISMANTLING AND REASSEMBLING INSTRUCTIONS

MANUFACTURED

by

THE S.U. CARBURETTER COMPANY LIMITED

WOOD LANE

ERDINGTON

BIRMINGHAM 24

TELEPHONE: ERDINGTON 7371 (9 lines)

TELEGRAMS: CARBURFLEX, BIRMINGHAM



THE S.U. TYPE AUF 400 RANGE PUMP

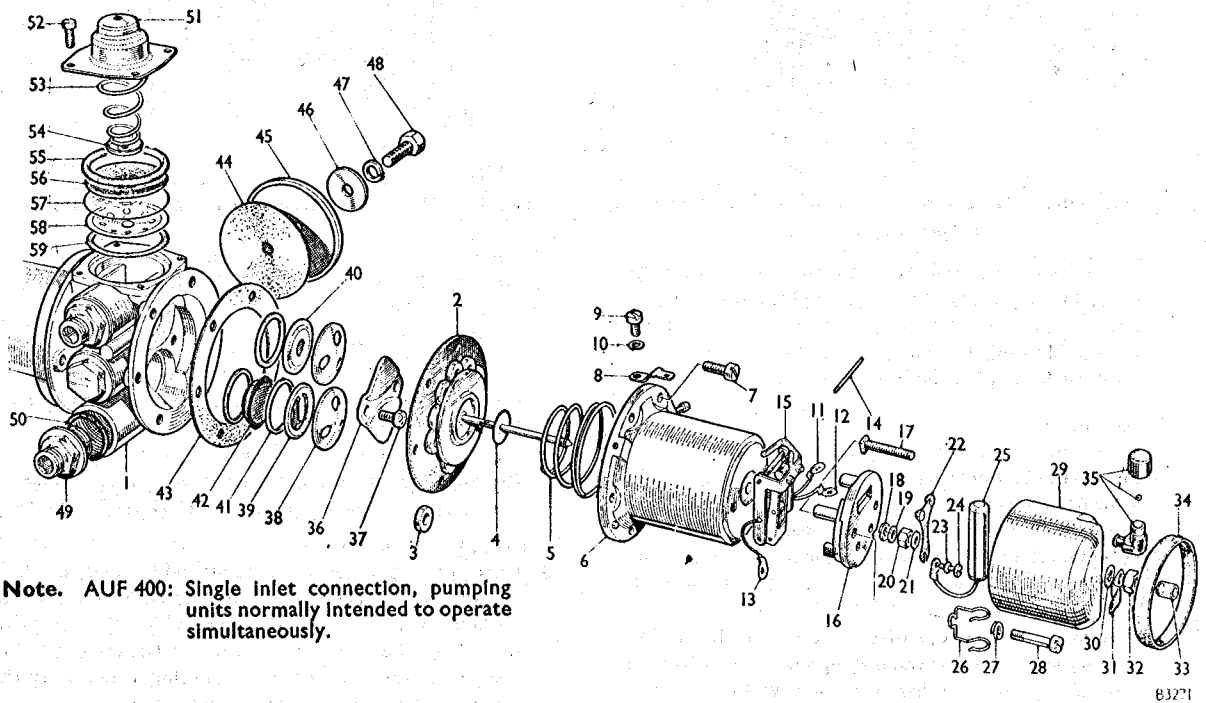

Note. AUF 400: Single inlet connection, pumping units normally intended to operate simultaneously.

No.	Description	No.	Description	No.	Description
1.	Pump body.	21.	Washer—end cover seal.	41.	Washer—sealing.
2.	Diaphragm and spindle assembly.	22.	Contact blade.	42.	Filter.
3.	Roller—armature centralizing.	23.	Washer—5 B.A.	43.	Gasket—diaphragm.
4.	Washer—impact.	24.	Screw—contact blade—5 B.A.	44.	Joint—inlet air bottle cover.
5.	Spring—armature.	25.	Condenser.	45.	Cover—inlet air bottle.
6.	Housing—coil.	26.	Clip—condenser.	46.	Washer—dished.
7.	Screw—securing housing—2 B.A.	27.	Washer—spring—2 B.A.	47.	Washer—spring.
8.	Connector—earth.	28.	Screw—pedestal to housing—2 B.A.	48.	Screw—securing cover.
9.	Screw—4 B.A.	29.	End cover.	49.	Connection—inlet.
10.	Washer—spring—4 B.A.	30.	Washer—shakeproof.	50.	Washer—sealing.
11.	Tag—terminal—5 B.A.	31.	Connector—Lucar.	51.	Cover—delivery flow smoothing device.
12.	Tag—terminal—2 B.A.	32.	Nut—2 B.A.	52.	Screw—securing cover.
13.	Tag—earth—2 B.A.	33.	Sleeve—insulating.	53.	Spring—diaphragm.
14.	Pin—rocker pivot.	34.	Band—sealing.	54.	Cap—spring end.
15.	Rocker mechanism.	35.	Valve—vent.	55.	'O' ring—rubber.
16.	Pedestal.	36.	Plate—clamp.	56.	Diaphragm—rubber.
17.	Stud—terminal.	37.	Screw—plate.	57.	Diaphragm barrier—plastic.
18.	Washer—spring.	38.	Cap—valve.	58.	Plate—diaphragm.
19.	Washer—lead.	39.	Valve—inlet.	59.	Washer—sealing.
20.	Nut—terminal.	40.	Valve—outlet.		

DISMANTLING

Contact breaker

1. Remove the insulated sleeve (33), terminal nut (32), and connector (31), together with its shakeproof washer. Remove the tape seal (if fitted) and take off the end-cover.
2. Unscrew the 5 B.A. screw (24) which holds the contact blade (22) to the pedestal (16) and remove the condenser (25) (if fitted) from its clip. This will allow the washer (23), the long-coil lead (11), and the contact blade to be removed.

Coil housing and diaphragm

3. Unscrew the coil housing securing screws (7), using a thick-bladed screwdriver to avoid damaging the screw heads.
4. Remove the earthing screw (9).
5. The coil housing (6) may now be removed from the body (1). Next remove the diaphragm and spindle assembly (2) by taking hold of the diaphragm and unscrewing it anti-clockwise until the armature spring (5) pushes the diaphragm away from the coil housing. It is advisable to hold the housing over the bench so that the 11 brass rollers (3) will not fall on the floor. The diaphragm and its spindle are serviced as a unit and should not be separated.
6. Repeat these operations on the remaining pump unit.

Pedestal and rocker

7. Remove the end-cover seal washer (21), unscrew the terminal nut (20), and remove the lead washer (19). This will have flattened on the terminal tag and thread and is best cut away with cutting pliers or a knife. Unscrew the two 2 B.A. screws (28) holding the pedestal to the coil housing, remove the earth terminal tag (13) together with the condenser clip (26) (if fitted). Tip the pedestal and withdraw the terminal stud (17) from the terminal tag (12). The pedestal (16) may now be removed with the rocker mechanism (15) attached.
8. Push out the hardened steel pin (14) which holds the rocker mechanism to the pedestal and separate the two.
9. Repeat these operations on the remaining pump unit.

Body and valves

10. Unscrew the two Phillips screws (37) securing the valve clamp plate (36), remove the valve caps (38), valves (39) and (40), sealing washers, and filter (42).

Note. Dismantling of the delivery flow-smoothing device should only be undertaken if the operation of it is faulty, and if the necessary equipment for pressure-testing

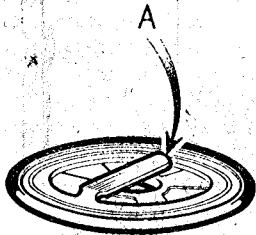

A.9304

Fig. 1. The valve (inlet and outlet)
A = $\frac{1}{16}$ in. (1.6 mm.)

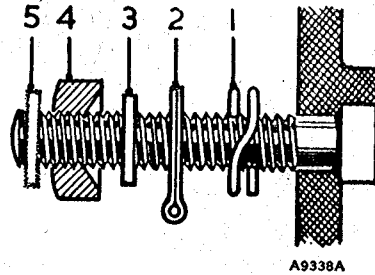

A9338A

Fig. 2. The correct assembly of components on the terminal stud

after assembly is available. On this understanding proceed as follows:

11. Remove the four 4 B.A. screws securing the delivery flow-smoothing device vented cover (51), remove the cover, the diaphragm spring (53), rubber 'O' ring (55), spring cap (54), diaphragm (56), barrier (57), diaphragm plate (58) and sealing washer (59).
12. Remove the single 2 B.A. screw (48), securing the inlet air bottle cover (45). Remove the cover and gasket (44).
13. Unscrew the inlet and outlet connections.

INSPECTION

If gum formation has occurred in the fuel used in the pump, the parts in contact with the fuel will have become coated with a substance similar to varnish. This has a strong stale smell and may attack the neoprene diaphragm. Brass and steel parts so affected can be cleaned by being boiled in a 20 per cent. solution of caustic soda, dipped in a strong nitric acid solution and finally washed in boiling water. Light alloy parts must be well soaked in methylated spirits and then cleaned.

1. Clean the pump and inspect for cracks, damaged joint faces, and threads.
2. Examine the plastic valve assemblies for kinks or damage to the valve plates. They can best be checked by blowing and sucking with the mouth.
3. Check that the narrow tongue on the valve cage, which is bent over to retain the valve and to prevent it being forced out of position, has not been distorted but allows a valve lift of approximately $\frac{1}{16}$ in. (1.6 mm.) (see Fig. 1).
4. Examine the delivery flow-smoothing device diaphragm, barrier, plate, spring, and spring cap for damage. If in doubt, renew the diaphragm.
5. Examine the inlet air bottle cover for damage.
6. Examine the valve recesses in the body for damage and corrosion; if it is impossible to remove the corrosion, or if the recess is pitted, the body must be discarded.
7. Clean the filter with a brush and examine for fractures, renew if necessary.
8. Examine the coil lead tag for security and the lead insulation for damage.
9. Examine the contact breaker points for signs of burning and pitting; if this is evident, the rocker assembly and spring blade must be renewed.
10. Examine the pedestal for cracks or other damage, in particular to the narrow ridge on the edge of the rectangular hole on which the contact blade rests.
11. If fitted, examine the non-return vent valve in the end-cover for damage, ensure that the small ball valve is free to move.

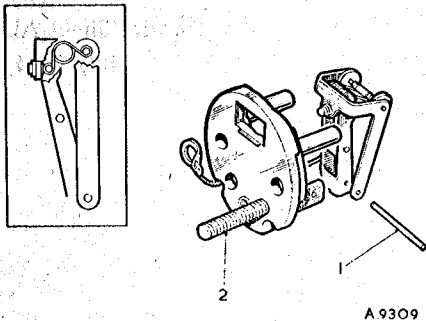

Fig. 3. Fitting the rocker assembly to the pedestal. (Inset) the correct position of the centre toggle spring

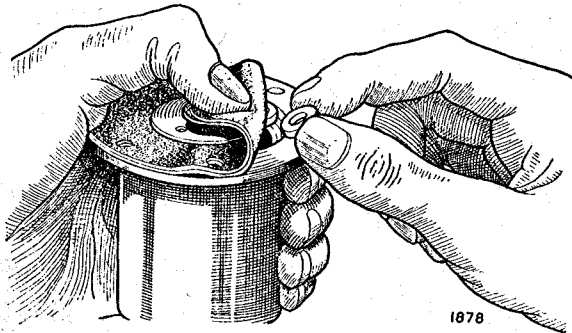

Fig. 6. Inserting the diaphragm centralizing rollers

12. [Examine the diaphragm for signs of deterioration.
13. Renew the following parts: all fibre and cork washers, gaskets, and 'O' section sealing rings, rollers showing signs of wear on periphery, damaged bolts, and unions.

ASSEMBLY

Pedestal and rocker

Note. The steel pin which secures the rocker mechanism to the pedestal is specially hardened and must not be replaced by other than a genuine S.U. part.

1. Invert the pedestal and fit the rocker assembly to it by pushing the steel pin (1) (Fig. 3) through the small holes in the rockers and pedestal struts. Then position the centre toggle so that, with the inner rocker spindle in tension against the rear of the contact points, the centre toggle

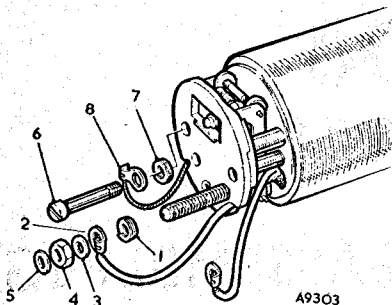

Fig. 4. Attaching the pedestal to the coil housing

spring is above the spindle on which the white rollers run. This positioning is important to obtain the correct 'throw over' action. It is also essential that the rockers are perfectly free to swing on the pivot pin and that the arms are not binding on the legs of the pedestal.

If necessary the rockers can be squared up with a pair of thin-nosed pliers.

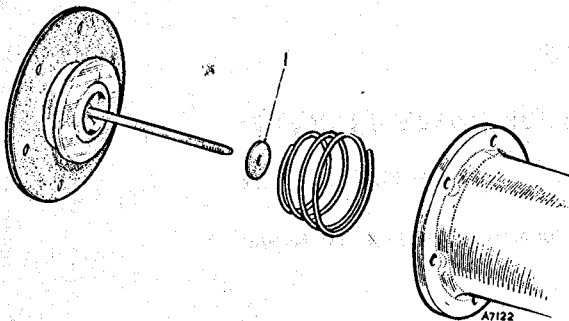

Fig. 5. Fitting the diaphragm to the coil housing. Note the impact washer (1)

2. Assemble the square-headed 2 B.A. terminal stud to the pedestal, the back of which is recessed to take the square head.
3. Assemble the 2 B.A. spring washer (1) (Fig. 4), and put the terminal stud through the 2 B.A. terminal tag (2), then fit the lead washer (3) and the coned nut with its coned face to the lead washer. (This makes better contact than an ordinary flat washer and nut.) Tighten the 2 B.A. nut and finally add the end-cover seal washer (5).
4. Assemble the pedestal to the coil housing (Fig. 4) by fitting the two 2 B.A. pedestal screws (6), ensuring that the spring washer (7) on the left-hand screw (9 o'clock position) is between the pedestal and the earthing tag (8). When a condenser is fitted, its wire clip base is placed under the earthing tag and the spring washer is dispensed with.
5. Tighten the screws, taking care to prevent the earthing tag (8) from turning, as this will strain or break the earthing flex. Do not overtighten the screws or the pedestal will crack. Repeat these operations on the remaining pedestal and rocker assembly.

Do not fit the contact blade at this stage.

Diaphragm assembly

6. Place the armature spring into the coil housing with its larger diameter towards the coil (Fig. 5).
7. Before fitting the diaphragm make sure that the impact washer is fitted to the armature. (This is a small neoprene washer that fits in the armature recess.) Do not use jointing compound or dope on the diaphragm.
8. Fit the diaphragm by inserting the spindle in the hole in the coil and screwing it into the threaded trunnion in the centre of the rocker assembly.
9. Screw in the diaphragm until the rocker will not 'throw over'; this must not be confused with jamming the armature on the coil housing internal steps.
10. Fit the 11 brass centralizing rollers (Fig. 6) by turning

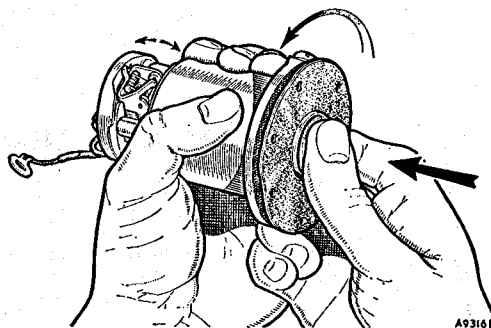

Fig. 7. Setting the diaphragm. Unscrew until the rocker just 'throws over'

back th
the coil
rocker
out.
On l
fingers
setting
caref.
11. Holdin
approx
diaphrag
pushing
pressin
until t
phragm
4 holes
is now
12. Press t
at the
to pre
housing
and is
tighter
Rep
assemb
Body com
13. In the
retaine
with se
In the
the fil
pumps
and a f



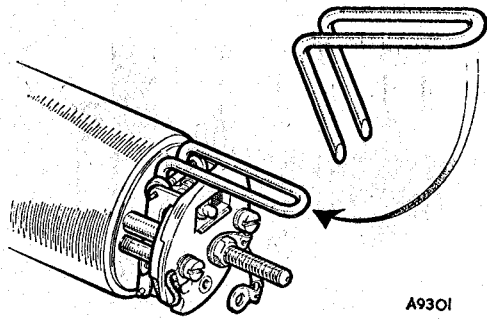

Fig. 8. Fitting the roller retaining fork

back the diaphragm edge and dropping the rollers into the coil recess. The pump should be held in the left hand, rocker end downwards, to prevent the rollers from falling out.

On later-type rocker mechanisms with adjustable fingers fit the contact blade and adjust the finger settings as described under those headings, then carefully remove the contact blade.

11. Holding the coil housing assembly in the left hand in an approximately horizontal position (see Fig. 7), push the diaphragm spindle in with the thumb of the right hand, pushing firmly but steadily. Unscrew the diaphragm, pressing and releasing with the thumb of the right hand until the rocker just 'throws over'. Now turn the diaphragm back (unscrew) to the nearest hole and then again 4 holes (two-thirds of a complete turn). The diaphragm is now correctly set.

12. Press the centre of the armature and fit the retaining fork at the back of the rocker assembly (Fig. 8). This is done to prevent the rollers from falling out when the coil housing is placed on the bench prior to fitting the body, and is not intended to stretch the diaphragm before tightening the body screws.

Repeat these operations on the remaining diaphragm assembly.

Body components

13. In the AUF 400 range of pumps the valve assemblies are retained internally in the body by a clamp plate secured with self-tapping screws (see Fig. 9). The inlet valve recess in the body is deeper than the outlet recess to allow for the filter and extra washer. Another feature of these pumps is the incorporation of an air bottle on the inlet and a flow-smoothing device on the delivery side.

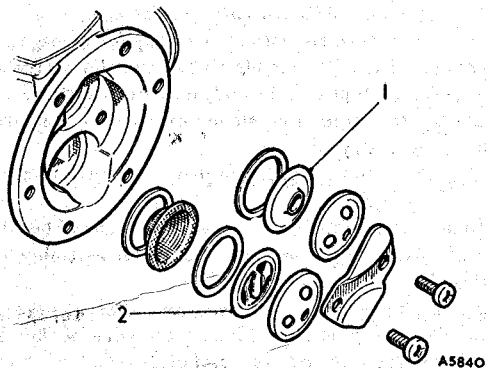

Fig. 9. The valve assembly, AUF 400 range
1. Outlet. 2. Inlet

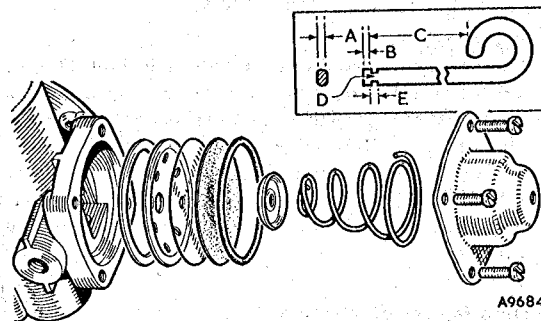

Fig. 10. The delivery flow smoothing device, AUF 400 range pumps

(Inset, enlarged) an assembly tool made from $\frac{1}{8}$ in. (3 mm.) dia. (10 s.w.g.) iron wire. A, B, and E = $\frac{1}{8}$ in. (1.6 mm.) C = 2 in. (50 mm.) D = .090 in. (2 mm.)

The inlet air bottle is a chamber in the body casting blanked off by a simple cover and joint washer held by a single screw. The delivery flow-smoothing device is formed by a perforated metal plate which is in contact with a plastic barrier backed by a rubber diaphragm, all held in position by a spring and end-cap retained by a vented cover. This assembly seals the delivery chamber in the body.

14. Screw in the inlet and outlet connections with their sealing rings. Assemble the outlet valve components into the outlet recess in the following order, first a joint washer, then the valve, tongue side downwards, then the valve cap.
15. Assemble the inlet valve into the inlet recess as follows: first a joint washer, then the filter, dome side downwards then another joint washer, followed by the valve assembly, tongue side upwards, then the valve cap.
16. Take care that both valve assemblies nest down into their respective recesses, place the clamp plate on top, and tighten down firmly to the body with the two screws.
17. Replace the inlet air bottle cover with its joint washer and tighten down the central screw.
18. Place the sealing washer in the bottom of the delivery flow-smoothing device recess (see Fig. 10), follow this with the perforated diaphragm plate, dome side downwards, then the plastic barrier, followed by the rubber diaphragm. Insert the 'O' section sealing ring into the recess and ensure that it seats evenly. Place the diaphragm spring, large ends towards the vented cover, into the cover, place the spring end-cap on the small end of the spring, pass the assembly tool (see Inset) through the cover, spring, and end cap and turn it through 90° so

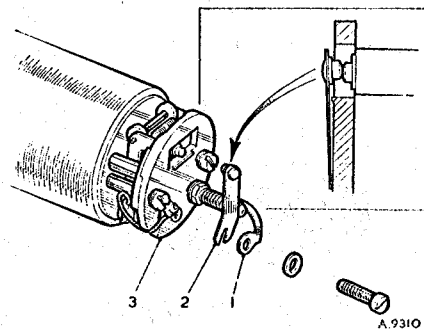

Fig. 11. Setting the correct relative position of blade and rocker contact points

Fig. 12.

that to
Finally
phragm
the ass
after d

Body attach

19. Fit the
20. Offer r
seating
21. Line up
cast lug
six 2 B
its Luc
22. Remo
the bo
retain
phragm
before
23. Tighte
diamet

Contact bl

24. Fit the
pedest
conden
lead ta
25. Adjust
are a li
the po
contact
over t
manne
attach
26. Tighte
correc

Contact ga

27. Check
coil ho
or ridg
pedest
attach
and be
reposit
ing of
mechar

Modified roc

28. Check

NOTE:

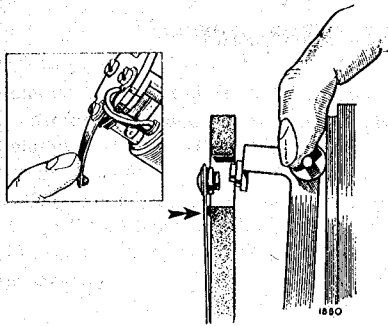

Fig. 12. Setting the contact blade to ensure contact with the pedestal ridge

that tension may be applied to the spring during assembly. Finally, fit the spring and cap assembly onto the diaphragm, tighten the four retaining screws and release the assembly tool. The pump should be pressure-tested after disturbance of the flow-smoothing device.

Body attachment

19. Fit the joint washer to the body, aligning the screw holes.
20. Offer up the coil housing to the body, ensuring correct seating between them.
21. Line up the six securing screw holes, making sure that the cast lugs on the coil housing are at the bottom, insert the six 2 B.A. screws finger-tight. Fit the earthing screw with its Lucar connector.
22. Remove the roller-retaining fork before tightening the body securing screws, making sure that the rollers retain their position; a displaced roller will cut the diaphragm. It is not necessary to stretch the diaphragm before tightening the securing screws.
23. Tighten the securing screws in sequence as they appear diametrically opposite each other.

Contact blade

24. Fit the contact blade (2) (Fig. 11) and coil lead (1) to the pedestal (3) with the 5 B.A. washer and screw. When a condenser is fitted the tag on it is placed under the coil lead tag.
25. Adjust the contact blade so that the contact points on it are a little above the contact points on the rocker when the points are closed (see Fig. 11), also that when the contact points make or break, one pair of points wipes over the centre line of the other in a symmetrical manner. As the contact blade is provided with a slot for the attachment screw, some degree of adjustment is possible.
26. Tighten the contact blade attachment screw when the correct setting is obtained.

Contact gap setting

27. Check that when the outer rocker is pressed onto the coil housing, the contact blade rests on the narrow rib or ridge which projects slightly above the main face of the pedestal (Fig. 12). If it does not, slacken the contact blade attachment screw, swing the blade clear of the pedestal, and bend it downwards a sufficient amount so that when repositioned it rests against the rib lightly, over-tensioning of the blade will restrict the travel of the rocker mechanism.

Modified rocker assemblies

28. Check the lift of the contact blade tip above the top of the

NOTE: The technical information contained in this Service Sheet supersedes any instruction previously published or authorized by the Company.

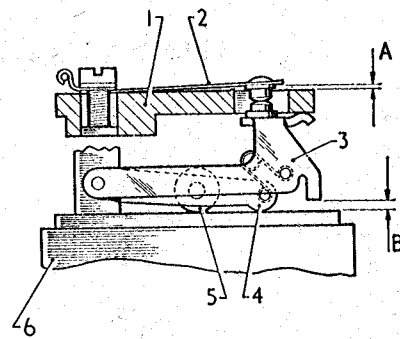

Fig. 13. The rocker finger settings on modified rocker assemblies

- | | |
|-------------------|------------------|
| 1. Pedestal. | 4. Inner rocker. |
| 2. Contact blade. | 5. Trunnion. |
| 3. Outer rocker. | 6. Coil housing. |
- A = .035 in. (.9 mm).
B = .070 in. (1.8 mm).

pedestal (A) (Fig. 13) with a feeler gauge, bending the stop-finger beneath the pedestal, if necessary, to obtain a lift of $.035 \pm .005$ in. ($.9 \pm .13$ mm.).

29. Check the gap between rocker finger and coil housing (B) (Fig. 13) with a feeler gauge, bending the stop-finger, if necessary, to obtain a gap of $.070 \pm .005$ in. ($1.8 \pm .13$ mm.).

Earlier-type rocker assemblies

30. Check the gap between the points indirectly by carefully holding the contact blade against the rib on the pedestal without pressing against the tip (see Fig. 14). Then check if a .030 in. (.8 mm.) feeler will pass between the fibre rollers and the face of the coil housing. If necessary the tip of the blade can be set to correct the gap.

End-cover

31. Tuck all spare cable into position so that it cannot foul the rocker mechanism. Ensure that the end-cover seal washer is in position on the terminal stud, fit the bakelite end-cover and lock washer, secure with the brass nut, fit the terminal tag or connector, and the insulated sleeve.
32. The pump is now ready for test (see leaflet AUA 213 A). After test replace the rubber sealing band over the end cover gap and seal with adhesive tape. This may be removed to improve ventilation when the pump is mounted internally in a moisture-free region but must be retained otherwise.

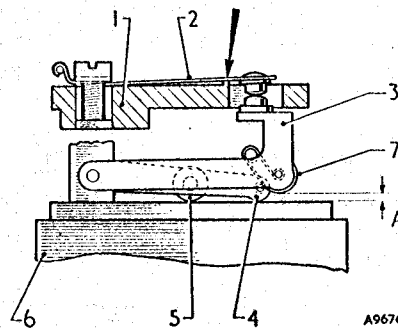

Fig. 14. The contact gap setting on earlier-type rocker assemblies

- | | |
|-------------------|------------------|
| 1. Pedestal. | 4. Inner rocker. |
| 2. Contact blade. | 5. Trunnion. |
| 3. Outer rocker. | 6. Coil housing. |
- A = .030 in. (.8 mm.).