

THE



FUEL PUMP

Type  
LCS

# DESCRIPTION AND FAULT DIAGNOSIS

MANUFACTURED

by

**THE S.U. CARBURETTER COMPANY LIMITED**

WOOD LANE

ERDINGTON

BIRMINGHAM 24

TELEPHONE: ERDINGTON 7371 (9 lines)

TELEGRAMS: CARBURFLEX, BIRMINGHAM



© THE BRITISH MOTOR CORPORATION LIMITED 1965

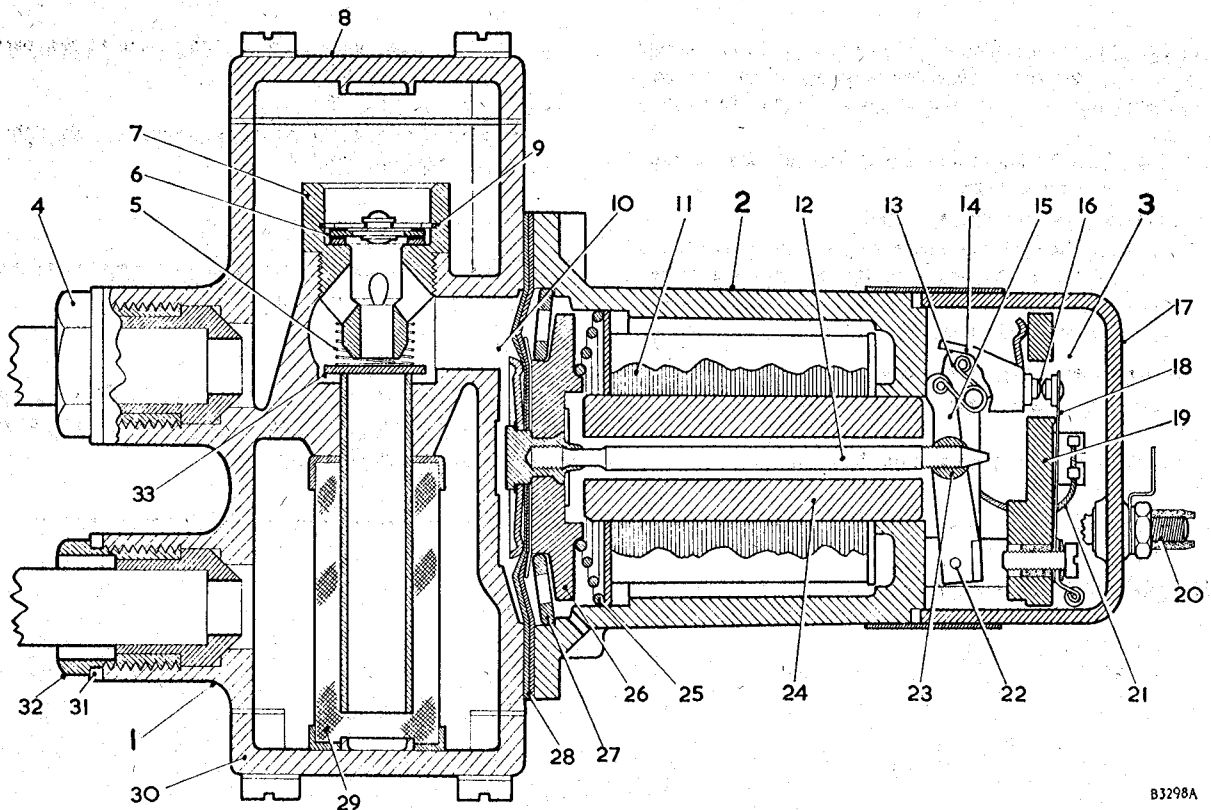

For references see text

B3298A

### INSTALLATION

The 'LCS' type pump can be mounted at any point between the region of the carburetter and the region of the rear tank. In the vertical plane it should be level, with or just below, the carburetter, the pipe lines being kept as short as possible. The pump should not be exposed to heat radiation from exhaust manifolds.

On later pumps a rubber sealing ring (31) has been introduced for fitment to the inlet and outlet unions before they are screwed into the body; this prevents the ingress of water, particularly when the pump is fitted on an exposed part of the chassis.

When a pump is being connected it must be primed by disconnecting the fuel pipe at the carburetter until a flow is obtained.

### DESCRIPTION

The pump comprises three main assemblies: the body casting (1), the diaphragm, armature and magnet assembly (2), and the contact breaker assembly (3).

#### The body

The body (1) is an aluminum die casting to which is fitted a top and lower lid (8) and (30); these are secured by 2 B.A. screws. The lower lid retains the filter (29) and the top lid gives access to the outlet valve cage (7), which is screwed into the body casting. On later pumps the outlet valve (6) is a riveted assembly comprising a brass seating, a light spring, and a thin plastic valve disc with a spring clip (9) retaining the valve on a cork washer in the valve cage. The inlet valve (33) is a plain brass disc which is held on a seating formed in the body casting by a light spring (5), retained by the outlet valve cage. On earlier pumps the outlet valve is a plain brass disc held into the outlet valve cage by a spring clip; the inlet valve is also a brass disc on a seating formed in the body casting but no spring

is fitted. An inlet and outlet connection (32) and (4) respectively are provided on the side of the body casting.

The space between the valves on both types is connected to the pumping chamber (10), formed by a shallow depression in the face of the body casting and bounded by the diaphragm (28).

#### The diaphragm, armature, and magnet assembly

The diaphragm (28) is clamped at its outer edge between the coil housing (2) and the body, and attached at its centre to the iron armature (26). The armature spindle (12) passes freely through the magnet core (24) and is screwed into a trunnion (23) carried by the inner rocker (15). Eleven spherically-edged rollers (27) are fitted between the coil housing and the armature; these centralize the armature in the housing and allow freedom of movement in a longitudinal direction.

#### The contact breaker assembly

This consists of a bakelite pedestal moulding (19) which carries two rockers, outer (14) and inner (15), both hinged to the moulding at one end by the rocker spindle (22), and interconnected at their top ends by two small toggle springs (13) arranged to give a 'throw-over' action. The inner rocker, as mentioned, carries a trunnion into which the armature spindle is screwed. The outer rocker (14) is fitted with one or two tungsten points (16) which contact other tungsten points carried by the spring blade (18). One end of the coil (11) is connected electrically to the spring blade and the other end is connected to the terminal stud (20). A short length of flexible wire (21) connects the outer rocker to one of the screws securing the pedestal moulding to the coil housing, thus providing an earth return. This must then be thoroughly earthed to the body or chassis of the vehicle via the earthing screw. A condenser may be fitted in a wire clip to one of the pedestal retaining screws, the tag from it being secured under the contact blade attachment screw. The contact breaker is contained in an end-cover moulding (17) secured to the pedestal by a nut and lock washer on the terminal stud.

## ACTION OF THE PUMP

When the pump is at rest the outer rocker (14) lies in the position illustrated and the tungsten points (16) make contact. When switched on, current passes from the terminal stud (20) through the coil, back to the spring blade (18), through the points, and so to earth, thus energizing the coil and attracting the armature (26). The armature, together with the diaphragm assembly, moves towards the coil, against pressure from the armature spring (25), drawing fuel through the inlet valve into the pumping chamber (10). When the armature has travelled well towards the end of its stroke the 'throw-over' mechanism operates and the outer rocker moves rapidly backwards, thus separating the contact points and breaking the circuit. The armature and diaphragm will now move away from the coil under the influence of the armature spring, thereby expelling the fuel through the outlet valve at a rate determined by the requirements of the engine. As the armature approaches the end of its stroke, away from the coil, the 'throw-over' mechanism again operates, the tungsten points re-make contact, and the cycle of operations is repeated.

## DIAPHRAGM AND CONTACT-BREAKER SETTINGS

A range of leaflets on Dismantling and Reassembling pumps is available. These should be referred to for operations not listed.

### Diaphragm

If the diaphragm has been disturbed, it is necessary to reset the position of the armature spindle in the rocker trunnion (23). This is done as follows:

- (1) On modified rocker assemblies set the two stop fingers as described under the heading 'Contact breaker'.
- (2) Slacken the screw securing the contact blade (18) and swing the blade to one side, so that the points no longer make contact.
- (3) Holding the coil housing (2) in the left hand, screw the diaphragm in generously with the thumb of the right hand, alternately pressing gently and turning until the rocker 'throw-over' ceases.
- (4) Unscrew the diaphragm one-sixth of a turn at a time in the same manner, slowly pressing and turning until the rocker 'throw-over' just operates.
- (5) At this point, continue unscrewing until the nearest securing screw hole is just lined up, and then again four holes (two-thirds of a complete turn). The diaphragm is now correctly set.
- (6) The contact blade, previously swung to one side, should now be replaced in its correct position. The slot for the attachment screw allows a degree of adjustment so that when correctly positioned, as the outer rocker operates to make or break the contacts, one pair of points wipes over the centre-line of the other in a symmetrical manner.

### Contact breaker

Check that when the outer rocker is pressed on to the coil housing, the contact blade rests on the narrow rib which projects slightly above the main face of the pedestal. If it does not, slacken the contact blade attachment screw, swing the blade clear of the pedestal, and bend it downwards a sufficient amount so that when repositioned it rests against the rib lightly; over-tensioning of the blade will restrict the travel of the rocker mechanism.

### Modified rocker assemblies

(Identified by stop fingers fitted to outer rockers.) Check the lift of the blade above the top of the pedestal with a feeler gauge, bending the stop finger beneath the pedestal, if necessary, to obtain a lift of  $.035 \pm .005$  in. ( $.9 \pm .13$  mm.).

Check the gap between the rocker finger and coil housing with a feeler gauge bending the stop finger, if necessary, to obtain a gap of  $.070 \pm .005$  in. ( $1.8 \pm .13$  mm.).

### Earlier-type rocker assemblies

Check the gap between the points indirectly by carefully holding the contact blade against the rib on the pedestal without pressing against the tip of the blade. Then check if a  $.030$  in. ( $.8$  mm.) feeler will pass between the fibre rollers and the face of the coil housing. If necessary, the tip of the blade can be set to correct the gap.

## FAULT DIAGNOSIS

### 1. Suspected fuel feed failure

Disconnect the fuel line at the carburetter and check for flow.

- (a) If normal, examine for obstructed float-chamber needle seating or gummed needle.
- (b) If normal initially, but diminishing rapidly and accompanied by slow pump operation, check for correct tank venting by removing the filler cap. Inadequate venting causes a slow power stroke, with resultant excessive burning of contact points.
- (c) If reduced flow is accompanied by slow operation of the pump, check for any restriction on the inlet side of the pump, such as a clogged filter, which should be removed and cleaned. In the case of reduced flow with rapid operation of the pump, check for an air leak on the suction side, dirt under the valves, or faulty valve sealing washers.
- (d) If no flow, check for:

#### (i) Electrical supply

Disconnect the lead from the terminal and test for an electrical supply.

#### (ii) Faulty contact points

If electrical supply is satisfactory the bakelite cover should be removed to check that the tungsten points are in contact. The lead should then be replaced on the terminal and a short piece of bared wire put across the contacts. If the pump then performs a stroke the fault is due to dirt, corrosion, or maladjustment of the tungsten points.

#### (iii) Obstructed pipeline between fuel tank and pump

The inlet pipe should be disconnected; if the pump then operates, trouble is due to a restriction in the pipeline between the pump and the tank. This may be cleared by the use of compressed air after removing the fuel tank filler cap. It should be noted, however, that compressed air should not be passed through the pump, as this will cause serious damage to the valves.

#### (iv) Faulty diaphragm action

If the previous operations fail to locate the trouble, stiffening of the diaphragm fabric or abnormal friction in the rocker 'throw-over' mechanism is to be suspected. To remedy these faults, the coil housing should be removed and the diaphragm flexed a few times, taking care not to lose any of the 11 rollers under it. Prior to reassembly, it is advisable to apply a little thin oil to the 'throw-over' spring spindles at a point where they pivot in the brass rockers. The diaphragm armature assembly should then be assembled and set in accordance with the instructions given under that heading.

### 2. Noisy pump

**Air leaks.** If the pump is noisy in operation, an air leak at one or other of the suction lines may be the cause. Such a leak may be checked by disconnecting the fuel pipe from the carburetter and allowing the pump to discharge into a suitable container

with the end of the pipe submerged. The emission of continuous bubbles at this point will confirm the existence of an air leak. The fault should be rectified by carrying out the following procedure:

- (a) Check that all connections from the fuel tank to the pump are in good order.
- (b) Check that the inlet union is tight.
- (c) Check that the coil housing securing screws are well and evenly tightened. Air leaks on the suction side cause rapid operation of the pump and are the most frequent cause of premature failure.

### 3. Pump operates without delivering fuel

If the pump operates without delivering fuel the most likely causes are:

- (a) A serious air leak on the suction side, or,

(b) Foreign matter lodged under one of the valves, particularly under the inlet valve.

To remedy (a) see para. 2 above.

To remove any foreign matter lodged under the valves these should be removed for cleaning.

### GUARANTEE

The terms of the guarantee on this pump are precisely the same as those on the car to which it is fitted.

---

The technical information contained in this Service Sheet supersedes any previous instructions published or authorized on this subject by the Company.

---

AUTHORIZED DISTRIBUTOR: