

THE



FUEL PUMP

Type
L and H P single

DISMANTLING AND REASSEMBLING
INSTRUCTIONS

MANUFACTURED
by

THE S.U. CARBURETTER COMPANY LIMITED

WOOD LANE · ERDINGTON · BIRMINGHAM 24
TELEPHONE: ERDINGTON 7371 (9 lines) TELEGRAMS: CARBURFLEX, BIRMINGHAM



S.U. SERVICE SHEET No. AUA 228

© THE BRITISH MOTOR CORPORATION LIMITED, 1966

THE S.U. TYPE L AND HP SINGLE PUMP

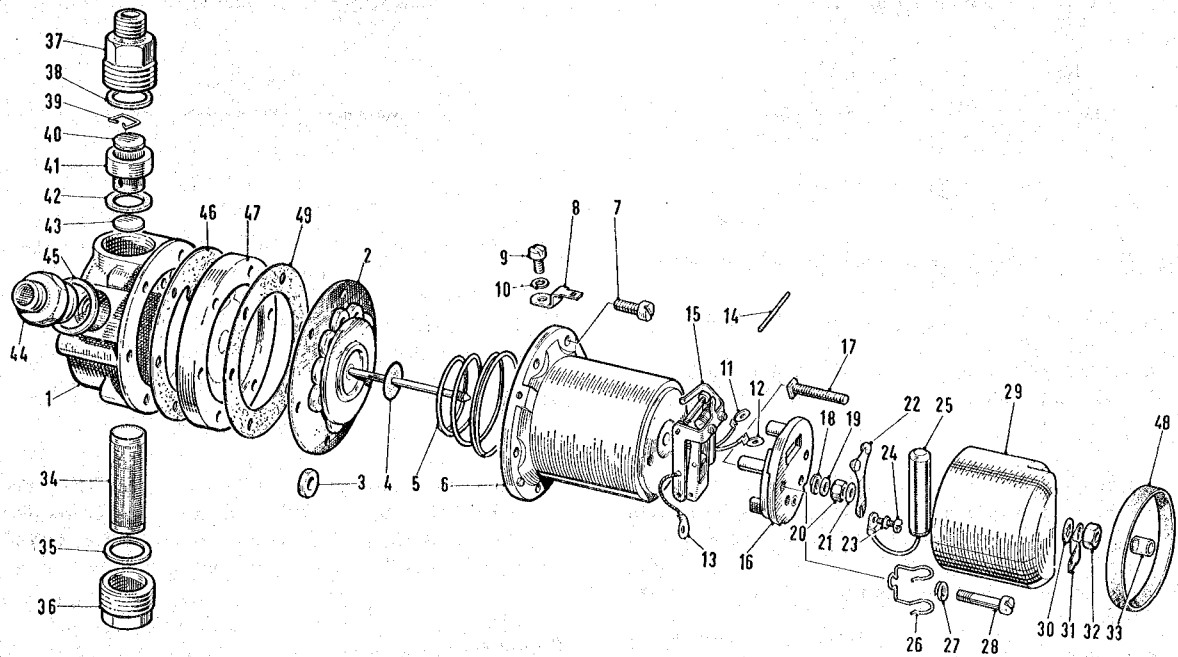

B3265

No.	Description	No.	Description	No.	Description
1.	Pump body.	17.	Stud—terminal.	33.	Sleeve—insulating.
2.	Diaphragm and spindle assembly.	18.	Washer—spring.	34.	Filter.
3.	Roller—armature centralizing.	19.	Washer—lead.	35.	Washer.
4.	Washer—impact.	20.	Nut—terminal.	36.	Plug—filter.
5.	Spring—armature.	21.	Washer—end cover seal.	37.	Connection—outlet.
6.	Housing—coil.	22.	Contact blade.	38.	Washer (Medium)—fibre.
7.	Screw—securing housing—2 B.A.	23.	Washer—5 B.A.	39.	Clip—spring.
8.	Connector—earth.	24.	Screw—contact blade—5 B.A.	40.	Valve—outlet.
9.	Screw—earth (4 B.A.—H, 2 B.A.—L).	25.	Condenser.	41.	Cage—outlet valve.
10.	Washer—spring.	26.	Clip—condenser.	42.	Washer (Thin)—fibre.
11.	Tag—terminal—5 B.A.	27.	Washer—spring, 2 B.A.	43.	Valve—inlet.
12.	Tag—terminal—2 B.A.	28.	Screw—pedestal to housing— 2 B.A.	44.	Connection—inlet.
13.	Tag—earth—2 B.A.	29.	End cover.	45.	Washer—fibre.
14.	Pin—rocker pivot.	30.	Washer—shakeproof—2 B.A.	46.	Gasket—joint.
15.	Rocker mechanism.	31.	Connector—Lucar.	47.	Plate—sandwich.
16.	Pedestal.	32.	Nut—2 B.A.	48.	Band—sealing.
				49.	Gasket—diaphragm.

DISMANTLING

Contact breaker

1. Remove the insulated knob or sleeve (33), terminal nut (32), and connector (31), together with its shakeproof washer. Remove the tape seal (if fitted) and take off the end-cover.
2. Unscrew the 5 B.A. screw (24) which secures the contact blade (22) to the pedestal (16) and remove the condenser (25) (if fitted) from its clip. This will allow the washer (23), the long-coil lead (11), and the contact blade to be removed.

Coil housing and diaphragm

3. Unscrew the coil housing securing screws (7), using a thick-bladed screwdriver to avoid damaging the screw heads.
4. Remove the earthing screw (9). On earlier pumps a 2 B.A. earthing stud (Fig. 1) was fitted in the 9 o'clock position on 12-volt pumps, and in the 12 o'clock position on 6-volt pumps, looking at the front or pedestal end of the pump.
5. The coil housing (6) may now be removed from the body (1). Next remove the diaphragm and spindle assembly (2) by taking hold of the diaphragm and unscrewing it anti-clockwise until the armature spring (5) pushes the diaphragm away from the coil housing. It is advisable to hold the housing over the bench so that the 11 brass rollers (3) will not fall onto the floor. The diaphragm and its spindle are serviced as a unit and should not be separated.

Pedestal and rocker

6. Remove the end-cover seal washer (21), unscrew the terminal nut (20), and remove the lead washer (19); this will have flattened on the terminal tag and thread and is best cut away with cutting pliers or a knife. Unscrew the two 2 B.A. screws (28), holding the pedestal to the coil housing, remove the earth terminal tag (13) together with the condenser clip (26) (if fitted). Tip the pedestal and withdraw the terminal stud (17) from the terminal tag (12). The pedestal (16) may now be removed with the rocker mechanism attached.
7. Push out the hardened steel pin (14) which holds the rocker mechanism to the pedestal and separate the two.

Body and valves

8. Remove the inlet union (44), the outlet union (37), the outlet valve cage (41), and the inlet valve disc (43). Remove the base plug (36) and filter (34).

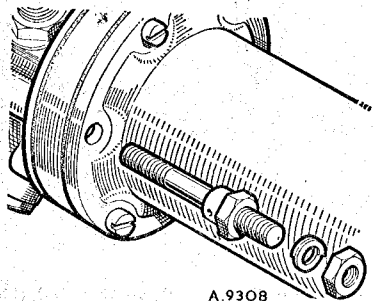

Fig. 1. The earthing stud on earlier pumps

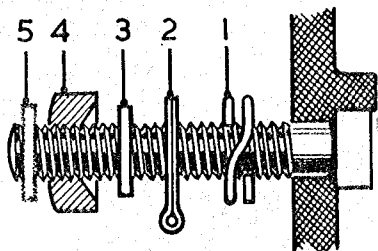

Fig. 2. The correct assembly of components on the terminal stud

INSPECTION

If gum formation has occurred in the fuel used in the pump, the parts in contact with the fuel will have become coated with a substance similar to varnish. This has a strong stale smell and may attack the neoprene diaphragm. Brass and steel parts so affected can be cleaned by being boiled in a 20 per cent. solution of caustic soda, dipped in a strong nitric acid solution and finally washed in boiling water. Light alloy parts must be well soaked in methylated spirits and then cleaned.

1. Clean the pump and inspect for cracks, damaged joint faces, and threads.
2. Remove the circlip in the outlet valve cage and examine the inlet and outlet valve discs for wear. Scrap if worn.
3. Examine the valve seat in the body and outlet valve cage for damage and corrosion; if it is impossible to remove the corrosion, or if the seat is pitted, the body or cage must be discarded.
4. Clean the filter with a brush and examine for fractures, renew if necessary.
5. Examine the coil lead tags for security and the lead insulation for damage.
6. Examine the contact breaker points for signs of burning and pitting; if this is evident, the rocker assembly and spring blade must be renewed.
7. Examine the pedestal for cracks or other damage, particularly to the narrow ridge on the edge of the rectangular hole on which the contact blade rests.
8. Examine the diaphragm for signs of deterioration.
9. Renew the following parts: all fibre washers, gaskets, and 'O' section sealing rings, rollers showing signs of wear on periphery, damaged bolts, and unions.

ASSEMBLY

Pedestal and rocker

Note. The steel pin which secures the rocker mechanism to the pedestal is specially hardened and must not be replaced by other than a genuine S.U. part.

1. Invert the pedestal and fit the rocker assembly to it by pushing the steel pin (1) (Fig. 3) through the small holes in the rockers and pedestal struts. Then position the centre toggle so that, with the inner rocker spindle in tension against the rear of the contact point, the centre toggle spring is above the spindle on which the white rollers run. This positioning is important to obtain the correct 'throw over' action; it is also essential that the rockers are perfectly free to swing on the pivot pin and

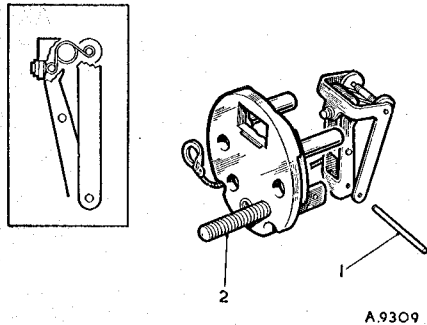

Fig. 3. Fitting the rocker assembly to the pedestal. (Inset) the correct position of the centre toggle spring

that the arms are not binding on the legs of the pedestal. If necessary the rockers can be squared up with a pair of thin-nosed pliers.

2. Assemble the square-headed 2 B.A. terminal stud to the pedestal, the back of which is recessed to take the square head.

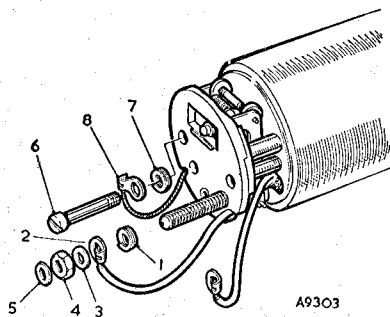

Fig. 4. Attaching the pedestal to the coil housing

3. Assemble the 2 B.A. spring washer (1) (Fig. 4), and put the terminal stud through the 2 B.A. terminal tag (2), then fit the lead washer (3) and the coned nut with its coned face to the lead washer. (This makes better contact than an ordinary flat washer and nut.) Tighten the 2 B.A. nut and finally add the end-cover seal washer (5).
4. Assemble the pedestal to the coil housing (Fig. 4) by fitting the two 2 B.A. pedestal screws (6), ensuring that the spring washer (7) on the left-hand screw (9 o'clock position) is between the pedestal and the earthing tag (8). When a condenser is fitted, its wire clip base is placed under the earthing tag and the spring washer is dispensed with.
5. Tighten the screws, taking care to prevent the earthing tag (8) from turning, as this will strain or break the earth-

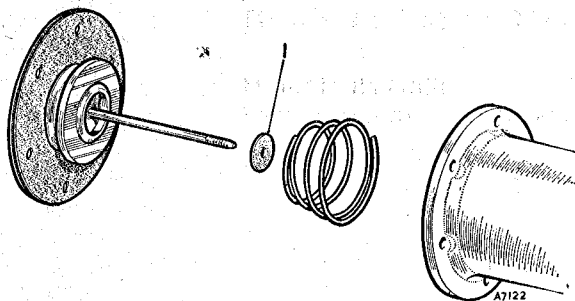

Fig. 5. Fitting the diaphragm to the coil housing. Note the impact washer (1)

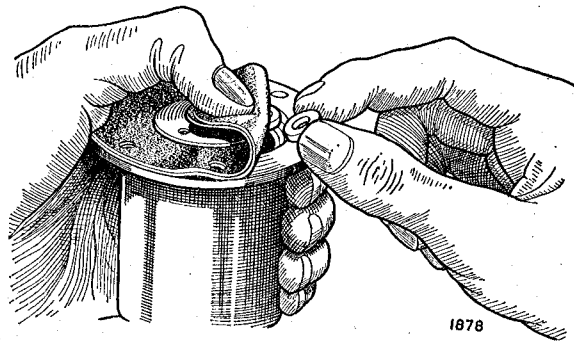

Fig. 6. Inserting the diaphragm centralizing rollers

ing flex. Do not overtighten the screws or the pedestal will crack.

Do not fit the contact blade at this stage.

Diaphragm assembly

6. Place the armature spring into the coil housing with its larger diameter towards the coil (Fig. 5).
7. Before fitting the diaphragm make sure that the impact washer is fitted to the armature. (This is a small neoprene washer that fits in the armature recess.) Do not use jointing compound or dope on the diaphragm.
8. Fit the diaphragm by inserting the spindle in the hole in the coil and screwing it into the threaded trunnion in the centre of the rocker assembly.
9. Screw in the diaphragm until the rocker will not 'throw over'; this must not be confused with jamming the armature on the coil housing internal steps.
10. Fit the 11 brass centralizing rollers (Fig. 6) by turning back the diaphragm edge and dropping the rollers into the coil recess. The pump should be held in the left hand, rocker end downwards, to prevent the rollers from falling out.

On later-type rocker mechanisms with adjustable fingers fit the contact blade and adjust the finger settings as described under those headings, then carefully remove the contact blade.

11. Holding the coil housing assembly in the left hand in an approximately horizontal position (see Fig. 7), push the diaphragm spindle in with the thumb of the right hand, pushing firmly but steadily. Unscrew the diaphragm, pressing and releasing with the thumb of the right hand until the rocker just 'throws over'. Now turn the diaphragm back (unscrew) to the nearest hole and again 4 holes (two-thirds of a complete turn). The diaphragm is now correctly set.

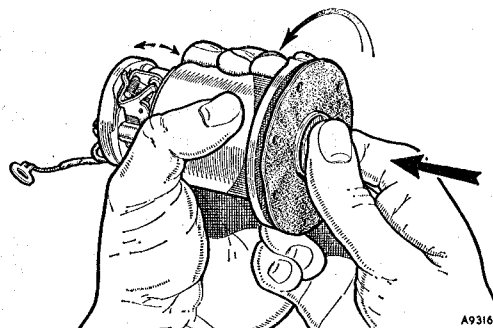

Fig. 7. Setting the diaphragm. Unscrew until the rocker just 'throws over'

12. Press at the to pr housi and tight

Body cor

Note.- 4-hole dri L type.

13. Asser valve disc circli valve cage

14. Drop ward inser in pe screw White

Body att

15. Place lining sandv diaph

16. Offer and conn

17. Line the t inser screw



Fig.

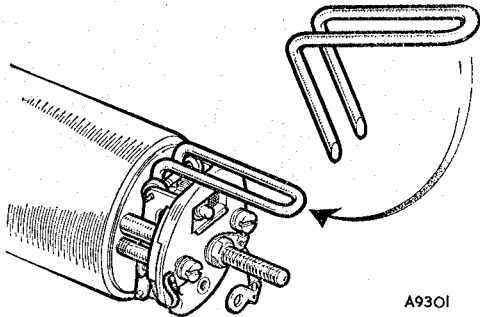

Fig. 8. Fitting the roller retaining fork

12. Press the centre of the armature and fit the retaining fork at the back of the rocker assembly (Fig. 8). This is done to prevent the rollers from falling out when the coil housing is placed on the bench prior to fitting the body, and is not intended to stretch the diaphragm before tightening the body screws.

Body components

Note.—Outlet valve cages may be identified by the 4-hole drilling of the HP type and the 2-hole drilling of the L type.

13. Assemble the brass valve disc (4) (Fig. 9) to the outlet valve cage, (3) making sure that the smooth face of the disc faces the valve seat, retain it in position with the circlip (5) which must be located in the groove in the valve cage. The valve must rattle freely when the valve cage is shaken.
14. Drop the other valve disc (1) (Fig. 9) smooth face downwards onto the inlet valve seat in the body of the pump, insert the thin fibre washer (2), drop the valve cage (3) in position, insert the medium fibre washer (6), then screw in the outlet union (7), and tighten with a $\frac{3}{8}$ -in. Whitworth ring or box spanner. Fit the inlet union.

Body attachment

15. Place the sandwich plate gasket on the face of the body, lining up the holes in the body and gasket; fit the sandwich plate, concave face to diaphragm with the diaphragm gasket, again lining up the holes.
16. Offer up the coil housing to the body and sandwich plate and ensure correct seating between them. Outlet connection to the top and filter plug at bottom.
17. Line up the six securing screw holes, making sure that the two cast lugs on the coil housing are at the bottom, insert the six 2 B.A. screws finger-tight. Fit the earthing screw with its Lucar connector.

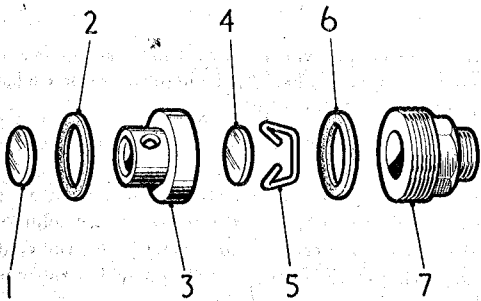

Fig. 9. The valve assembly, L and HP single pumps

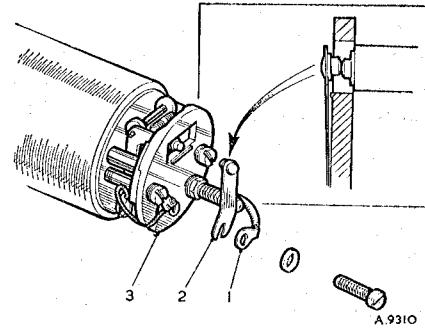

Fig. 10. Setting the correct relative position of blade and rocker contact points

Note 1. On short HP pumps the earthing screw has been reduced in size from 2 B.A. to 4 B.A. thus an L-type pump can be identified externally by the 2 B.A. earthing screw.

Note 2. Earlier L and HP pumps have an earthing stud fitted in the 9 o'clock position (see Fig. 1).

18. Remove the roller retaining fork before tightening the body securing screws, making sure that the rollers retain their position; a displaced roller will cut the diaphragm. It is not necessary to stretch the diaphragm before tightening the securing screws.
19. Tighten the securing screws in sequence as they appear diametrically opposite each other.

Contact blade

20. Fit the contact blade (2) (Fig. 10) and coil lead (1) to the pedestal (3) with the 5 B.A. washer and screw. When a condenser is fitted the tag on it is placed under the coil lead tag.
21. Adjust the contact blade so that the contact points on it are a little above the contact points on the rocker when the points are closed (see Fig. 10), also that when the contact points make or break, one pair of points wipes over the centre line of the other in a symmetrical manner.

As the contact blade is provided with a slot for the attachment screw, some degree of adjustment is possible.

22. Tighten the contact blade attachment screw when the correct setting is obtained.

Contact gap settings

23. Check that when the outer rocker is pressed onto the coil housing, the contact blade rests on the narrow rib or ridge which projects slightly above the main face of the

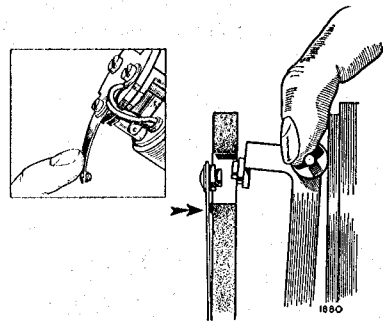

Fig. 11. Setting the contact blade to ensure contact with the pedestal ridge

Fig. 1.

- 1.
- 2.
- 3.
- A=

ped
atta
and
repe
ing
mec

Modified

24. Che
ped
stop
a lif
25. Che
(B)
if ne
mm.

Earlier-ty

26. Che
hold

Note.
on this su

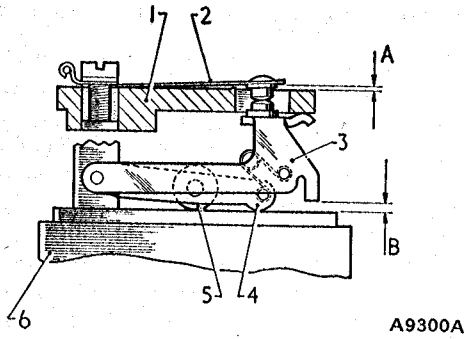

Fig. 12. The rocker finger settings on modified rocker assemblies

- | | |
|-------------------|------------------|
| 1. Pedestal. | 4. Inner rocker. |
| 2. Contact blade. | 5. Trunnion. |
| 3. Outer rocker. | 6. Coil housing. |
- A = .035 in. (.9 mm.).
B = .070 in. (1.8 mm.).

pedestal (Fig. 11). If it does not, slacken the contact blade attachment screw, swing the blade clear of the pedestal, and bend it downwards a sufficient amount so that when repositioned it rests against the rib lightly, over-tensioning of the blade will restrict the travel of the rocker mechanism.

Modified rocker assemblies

24. Check the lift of the contact blade tip above the top of the pedestal (A) (Fig. 12) with a feeler gauge, bending the stop-finger beneath the pedestal, if necessary, to obtain a lift of $.035 \pm .005$ in. ($.9 \pm .13$ mm.).
25. Check the gap between rocker finger and coil housing (B) (Fig. 12) with a feeler gauge, bending the stop-finger, if necessary, to obtain a gap of $.070 \pm .005$ in. ($1.8 \pm .13$ mm.).

Earlier-type rocker assemblies

26. Check the gap between the points indirectly by carefully holding the contact blade against the rib on the pedestal

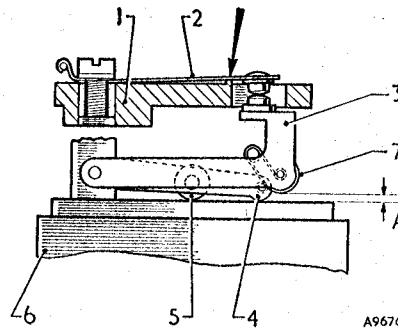

Fig. 13. The contact gap setting on earlier-type rocker assemblies

- | | |
|-------------------|------------------|
| 1. Pedestal. | 4. Inner rocker. |
| 2. Contact blade. | 5. Trunnion. |
| 3. Outer rocker. | 6. Coil housing. |
- A = .030 in. (.8 mm.).

without pressing against the tip (see Fig. 13). Then check if a .030 in. (.8 mm.) feeler will pass between the fibre rollers and the face of the coil housing. If necessary the tip of the blade can be set to correct the gap.

End-cover

27. Tuck all spare cable into position so that it cannot foul the rocker mechanism. Ensure that the end-cover seal washer is in position on the terminal stud, fit the bakelite end-cover and lock washer, secure with the brass nut, fit the terminal tag or connector, and the insulated knob or sleeve.
28. The pump is now ready for test (see leaflet AUA 213 A). After test replace the rubber sealing band over the end cover gap and seal with adhesive tape. This may be removed to improve ventilation when the pump is mounted internally in a moisture-free region but must be retained otherwise.

Note.—The technical information contained in this Service Sheet supersedes any instruction previously published or authorized on this subject by the Company.