



DATE: 10/1/69

BRITISH LEYLAND MOTORS INC.
600 Willow Tree Road • Leonia • New Jersey 07605

SUBJECT:

Austin-MG Special Service Tools
Minimum Tool Requirements

MODELS:

All Models

This Bulletin lists the B.L.M.I. Minimum Tool Requirements as of October 15, 1969. It is essential that all dealers have these tools to properly service Austin-MG vehicles.

It has been proven that proper tools save you money and enable you to meet flat rate time schedules.

Attached is a Tool Order Check List. Please fill out as soon as possible and forward to your Distributor.

For additional tools available, please refer to Supplementary List, Technical Service Bulletin Number 2 G 41.

All tools are color coded with painted dots:

Red - All A Series consisting of Sprite, Midget,
MG 1100 and Austin America

White - All B Series consisting of MGB

Blue - All C Series consisting of Austin Healey 3000
and MGC

2 Red Dots - Automatic A Series

If tool has all colors, it is applied to all models.

18G 34A - Bevel Pinion Flange Wrench

The two sets of tapered pins on this tool ensure that it will hold the propeller shaft flange against rotation while the flange nut is released or tightened on semi-floating or three-quarter-floating axles.



18G 134 - Bearing and Oil Seal Replacer
(basic tool)

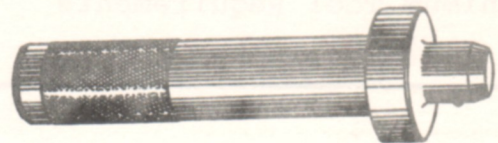

18G 134BD - Timing Case Oil Seal Replacer Adaptor

The fitting of the primary gear and timing case oil seals to their respective positions must be carried out with extreme care. Both the handle (Part No. 18G 134) and adaptors (Part Nos. 18G 134BC and 18G 134BD) must be used to ensure that the seals are fitted to their respective positions correctly and without damage.



18G 152 - Rear Hub Nut Spanner

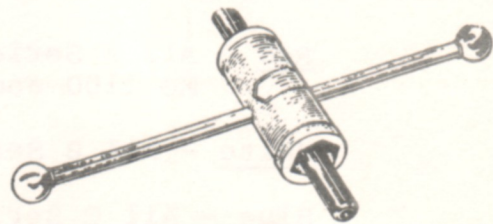

18G 178 - Roller Clutch Assembly Ring

This precision-made assembly ring is an essential tool for reassembling the roller clutch for the Laycock overdrive unit.

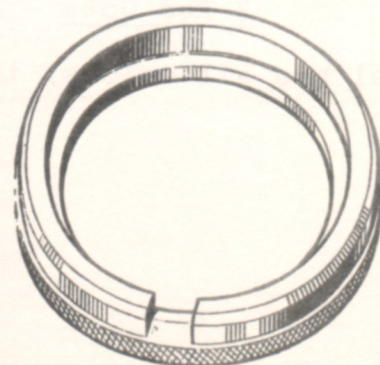

PART NO.	PRICE	AUSTIN AMERICA	MG 1100	SPRITE/ MIDGET	MGB	MGC	HEALEY 3000
18G 34A	\$13.26			*	*	*	*
18G 134	4.73	*	*	*	*	*	*
18G 134BD	4.14	*	*		*		
18G 152	24.67			*	*		
18G 178	11.09				*	*	*

18G 185 - Dummy Layshaft

This dummy mainshaft is essential when rebuilding the Laycock overdrive unit.



18G 251 - Hydraulic Pressure Gauge

When connected to the operating valve of the Laycock overdrive unit a pressure of between 430 and 460 lb./sq. in. (30.23 and 33.34 kg/cm²) should be indicated.

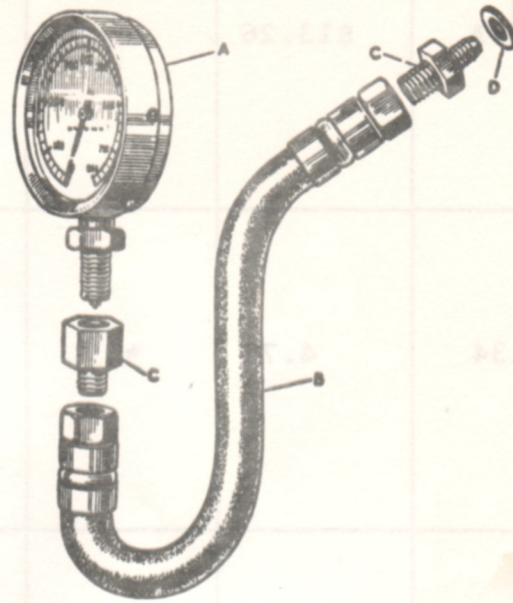

18G 251E - Adaptor Pressure Gauge

Use with Pressure Gauge and Pipe 18G 251 to pressure check the overdrive unit as fitted to the MGC and MGB MK II.

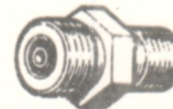

18G 257 - Circlip Pliers - Large

(HAC 64 Tip Set 4 Pieces)

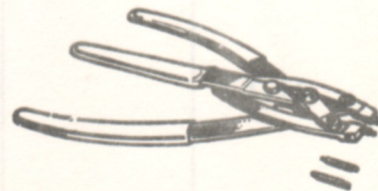

18G 258 - Rear Hub Nut Spanner

The long pilot locates in the axle tube to ensure an even pull on the thin octagonal hub nut.

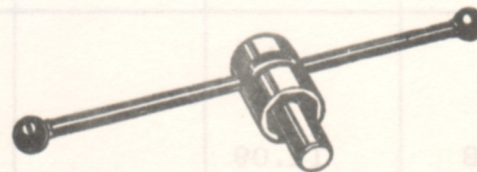

PART NO.	PRICE	AUSTIN AMERICA	MG 1100	SPRITE/ MIDGET	MGB	MGC	HEALEY 3000
18G 185	\$16.37					*	*
18G 251	17.93				*	*	*
18G 251E	4.05				*	*	
18G 257	15.31	*	*	*	*	*	*
18G 258	18.99						*

18G 284 - Impulse Extractor
UNF (basic tool)

This extractor with the adaptor positioned in the screwed end will remove the most difficult main bearing cap quickly and without damage.

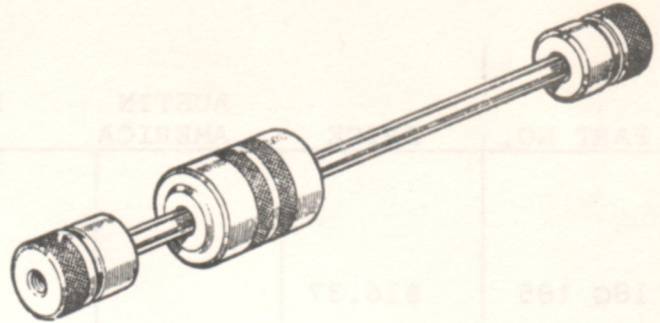

18G 284A - Main Bearing Cap Removal Adaptor

For use with impulse extractor 18G 284.

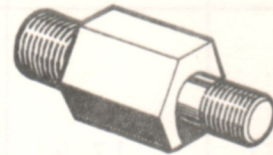

18G 284B - First Motion Shaft Remover Adaptor

This extractor with the adaptor positioned in the screwed end will withdraw both the first motion shaft and bearing, provided the drive gear has been removed and the bearing circlip extracted.

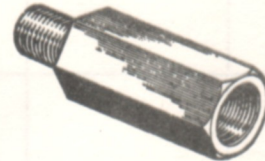

18G 304 - Front and Rear Hub Remover
(basic tool)

The remover 18G 304 is a basic tool for use with various adaptor bolts supplied separately. Screw the two adaptor bolts 18G 304B onto the wheel studs and insert the thrust pad into the axle tube. The rear hub can then be removed by screwing up the centre screw against the thrust pad.

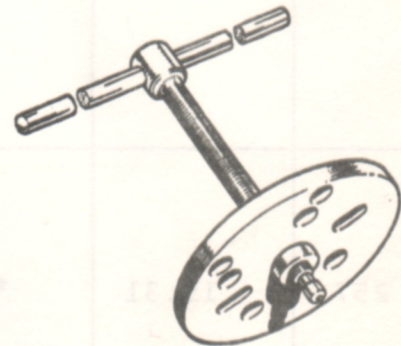

18G 304M - Flywheel and Clutch Remover Adaptor

18G 304M/1 Thrust Pad Also Fits 18G 304N
18G 304M/4 Center Screw Also Fits 18G 304N
18G 304M/5 Stud Set Includes Nuts & Washers

18G 304N
18G 304N/1 Stud Set Includes Nuts & Washers

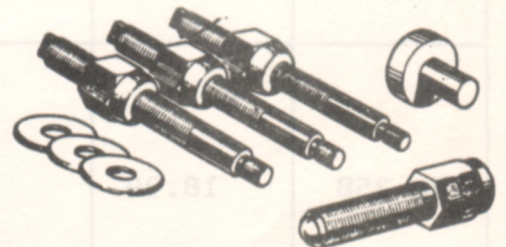

PART NO.	PRICE	AUSTIN AMERICA	MG 1100	SPRITE/ MIDGET	MGB	MGC	HEALEY 3000
18G 284	\$15.20	*	*		*		
18G 284A	2.69				*		
18G 284B	2.81	*	*				
18G 304	13.72	*	*	*	*	*	*
18G 304M 18G 304M/1 18G 304M/4 18G 304M/5	10.10 1.80 3.65 6.30		*				
18G 304N 18G 304N/1	12.64 6.30	*	*				

18G 363 - Hub Remover - Wire Wheels

Designed to withdraw left-hand and right-hand 'knock-on' hubs. The body is internally threaded with a left-hand thread in one end and a right-hand thread in the other.

12 T.P.I.

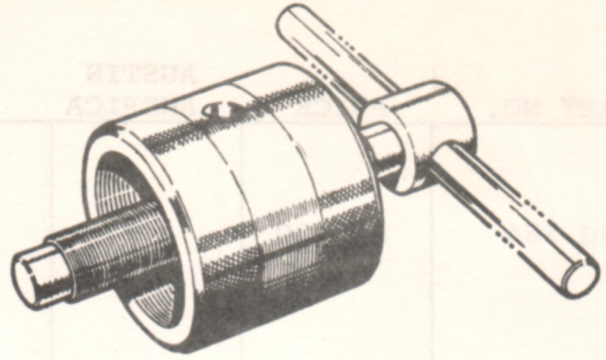
18G 502A - Pressure Gauge

Automatic

18G 502K - Pressure Hose

Automatic

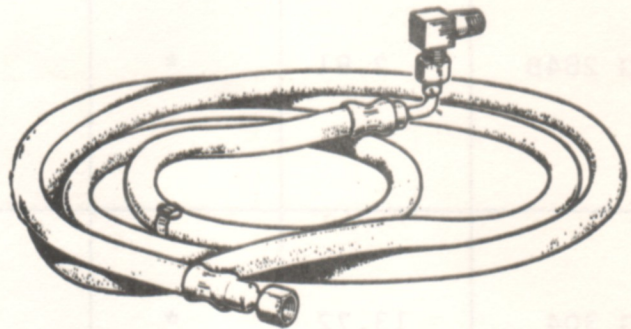
18G 579 - First and Third Motion
Shaft Bearing Replacer

HAC 63 - Washer

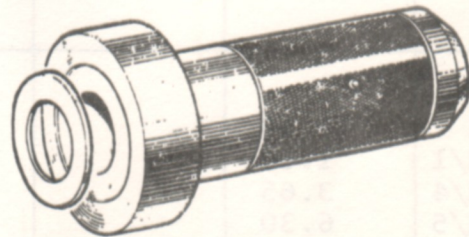

18G 587 - Socket



PART NO.	PRICE	AUSTIN AMERICA	MG 1100	SPRITE/ MIDGET	MGB	MGC	HEALEY 3000
18G 363	\$39.69			*	*		*
18G 502A	7.56	*				*	
18G 502K	16.80	*				*	
18G 579 HAC 63	5.43 .85	*	*				
18G 587	6.60	*	*				

18G 613 - Third Motion Shaft Bearing Remover

For use when removing the third motion shaft bearing to prevent damage to the housing bore.

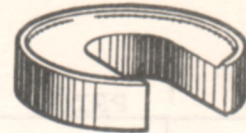
**18G 617A - Roller Bearing Outer Rear Remover and Replacer**

To remove bearing race of 1st motion shaft in flywheel housing. Instructions for use will be packed with tool and also printed in Workshop Manuals, (replacing 18G 617 which is now discontinued).

(18G 617A/2 Plug Only)

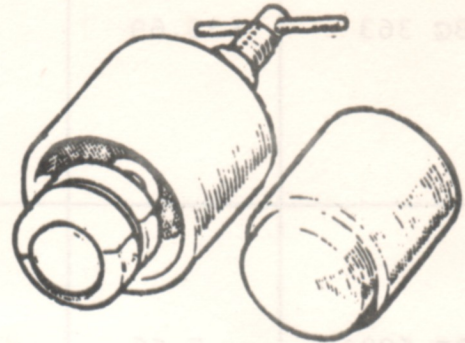
**18G 669 - Drive Shaft Coupling Flange Wrench**

For use when removing or replacing the flange retaining nuts, thus preventing possible damage to the transmission casing when using improvised methods.

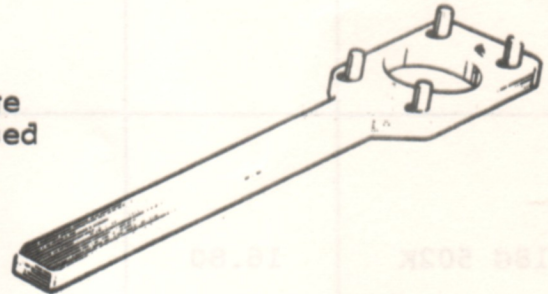
**18G 677C - Adaptor**

America Automatic

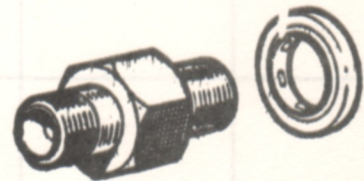
**18G 703 - The Hydrolastic Suspension Service Unit**

Service Parts Available for 18G 703

- 18G 703/A - Major Overhaul Seals and Gaskets
- 18G 703/B - Minor Overhaul Seals and Gaskets
- 18G 703/16 - Top Pressure Pump Valve
- 18G 703/25 - Bleed Valve Tap
- 18G 703/27 - Bleed Valve Body
- 18G 703/34 - Nylon Tube 6' 6"
- 18G 703/68 - Fluid Tank
- 18G 703/85 - No Loss Connector
- 18G 703/86 - Renrut Connector

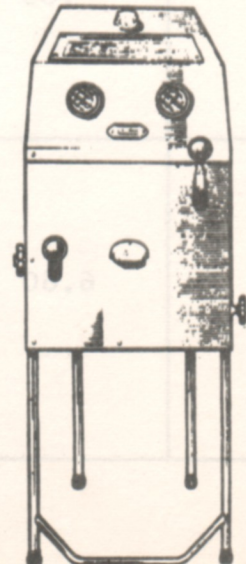

PART NO.	PRICE	AUSTIN AMERICA	MG 1100	SPRITE/ MIDGET	MGB	MGC	HEALEY 3000
18G 613	\$ 3.18	*	*				
18G 617A 18G 617A/2	10.52 1.70	*	*		*		
18G 669	5.76	*	*				
18G 677C	1.61	*					
18G 703	168.34						
18G 703/A	6.18						
18G 703/B	.80						
18G 703/16	1.44						
18G 703/25	.96	*	*				
18G 703/27	2.00						
18G 703/34	1.90						
18G 703/68	9.80						
18G 703/85	7.26						
18G 703/86	6.00						

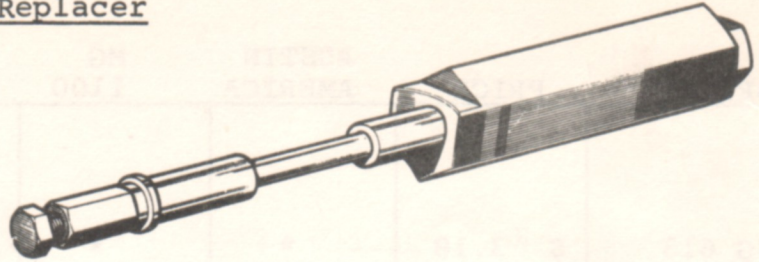
18G 1002 - Gudgeon Pin Remover/Replacer18G 1004 - Circlip Pliers

(HAC 65 Tip Set)

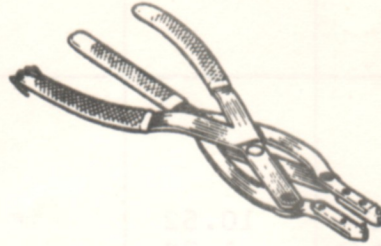
18G 1032 - Wire Wheel Hub Remover

Designed to withdraw left-hand and right-hand 'knock-on' hubs. The body is internally threaded with a left-hand thread in one end and a right-hand thread in the other.

8 T.P.I.

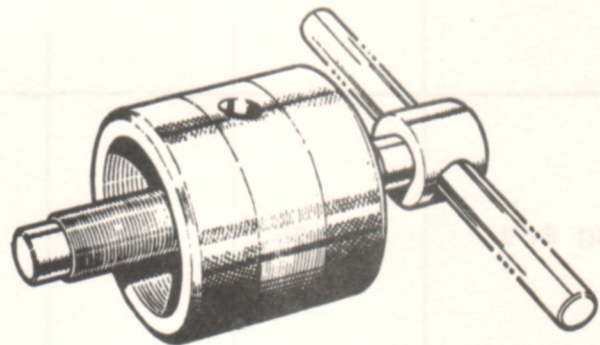
18G 1043 - Crankshaft Primary Gear
Oil Seal Protector Sleeve

For use when fitting the flywheel housing to prevent the clutch splines on the crankshaft primary gear damaging the oil seal. The two pilot studs must be screwed into the two bottom tapped holes in the cylinder block.

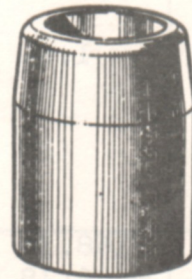

NOTE: This tool replaces 18G 570 which should not be used on late type cars.

PART NO.	PRICE	AUSTIN AMERICA	MG 1100	SPRITE/ MIDGET	MGB	MGC	HEALEY 3000
18G 1002	\$31.05	*		*			
18G 1004 HAC 65	8.07 5.60	*	*	*	*	*	*
18G 1032	34.58			*	*	*	*
18G 1043	6.44	*	*				

18G 1068 - Remover/Replacer Primary
Driver Gear Oil Seal, 13H 2934

18G 1068/04 - Center Screw
18G 1068/06 - Jaw Set

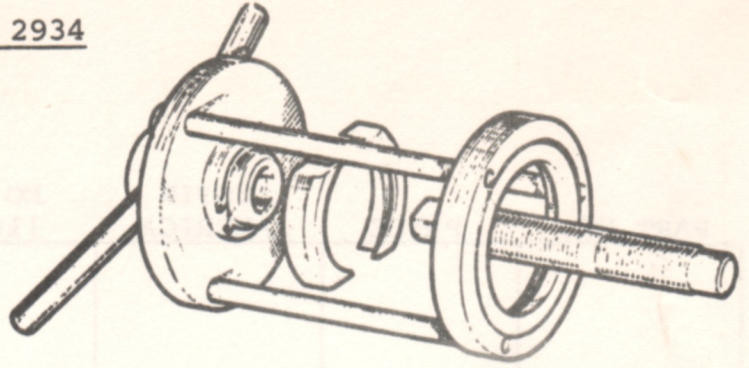

18G 1068A - Bolt Adaptor
America Automatic

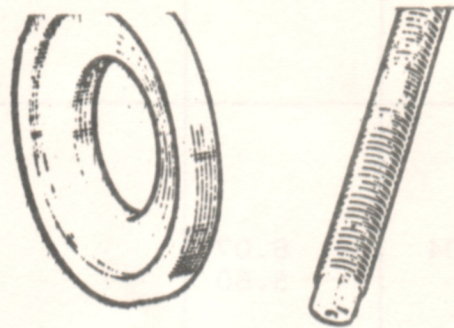

18G 1086 - Converter Remover

America Automatic
(HAC 66 Set = Three (3) Step Washers
and Six (6) Bolts)

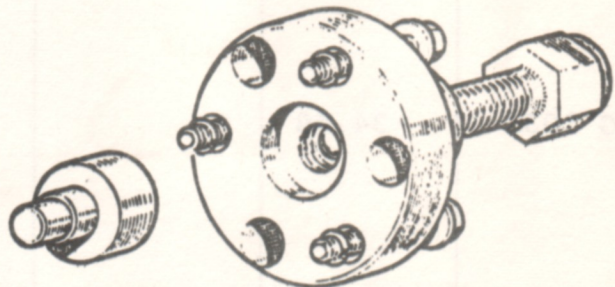

18G 1088 - Primary Gear Wrench
America Automatic

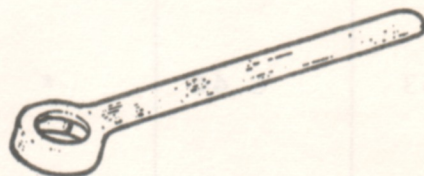

18G 1089 - Idler & Input Gauge Set

America Automatic
(HAC 62 Wax Only)

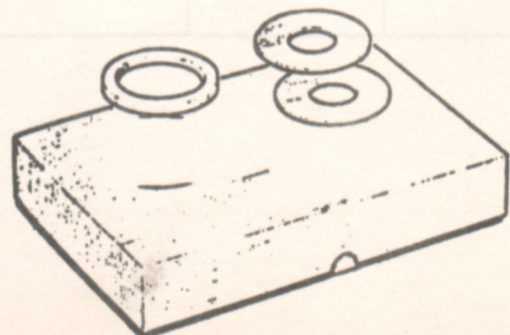

PART NO.	PRICE	AUSTIN AMERICA	MG 1100	SPRITE/ MIDGET	MGB	MGC	HEALEY 3000
18G 1068 18G 1068/04 18G 1068/06	\$21.12 2.50 5.60	*	*				
18G 1068A	7.56	*					
18G 1086 HAC 66	14.00 2.10	*					
18G 1088	16.10	*					
18G 1089 HAC 62	11.06 2.80	* *					

18G 1089A - Gauge Set Adaptor

America Automatic

18G 1094 - Oil Pump Pipes
Chest Alignment Tool

America Automatic

To position oil pump pipes before assembling transmission front cover.

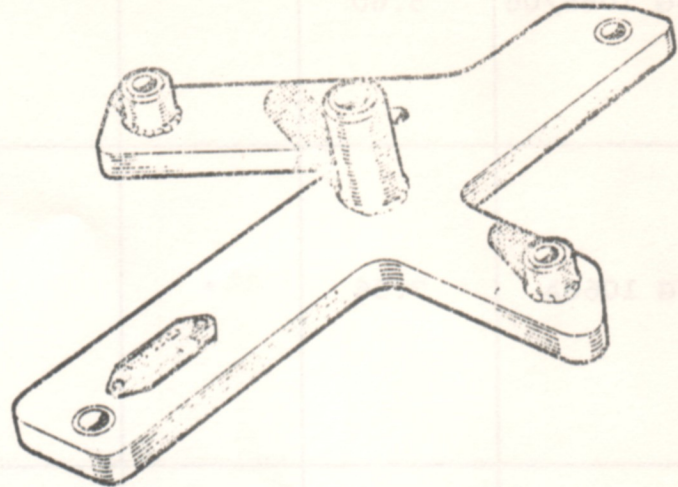

18G 1097 - Retainer Forward Clutch

To retain forward clutch when removing transmission front cover.

America Automatic

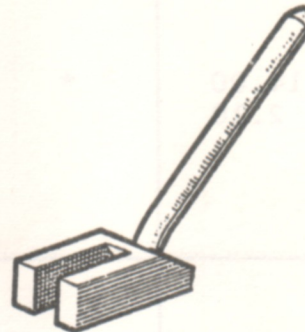
18G 1098 - Protector Sleeve

America Automatic

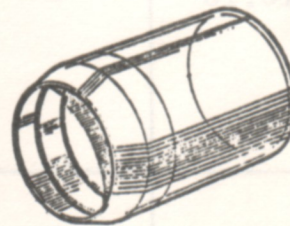
18G 1106 - Centralizer Governor Housing
To Front CoverTo centralize governor housing assembly to transmission front cover. This tool must be used when assembling auxiliary pump and/or governor to front cover.

America Automatic



PART NO.	PRICE	AUSTIN AMERICA	MG 1100	SPRITE/ MIDGET	MGB	MGC	HEALEY 3000
18G 1089A	\$ 7.00	*					
18G 1094	11.48	*					
18G 1097	5.04	*					
18G 1098	1.54	*					
18G 1106	7.32	*					

18G 1112 - Circlip Pliers

Circlip pliers for the tandem brake master cylinder.

18G 1117 - Pump Body Holder and Seat Remover

To hold oil pump body when re-assembling overdrive unit.

18G 1118 - Oil Pump Body Socket

To remove oil pump body plug from overdrive unit.

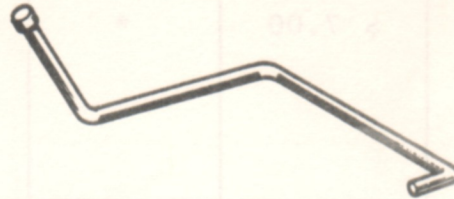
HAC 60 - Synchro Check

To synchronize dual carburetters.

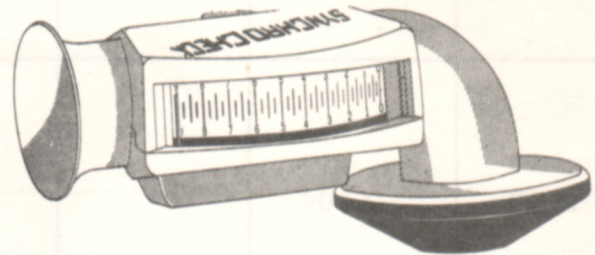
HAC 61 - S.U. Carburetter Piston Loading Tool

(HAC 61A Tip Set)

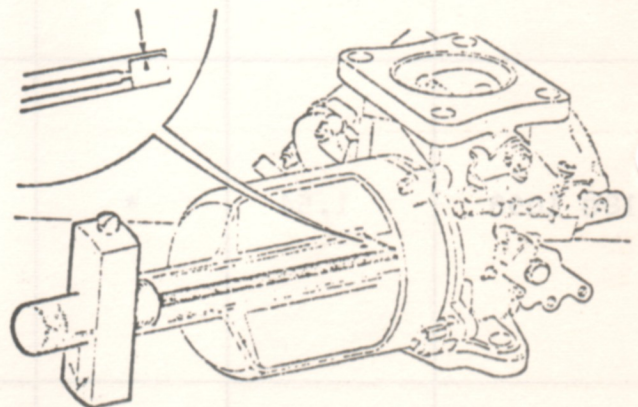
HAC 67 - Hexagonal Knockoff Wrench

This heavy duty wrench has been designed for workshop use. Made out of 1/4" high grade steel plate - handle angled and reinforced with 3/4" lug. Fits all BMC models with hexagonal knockoffs.

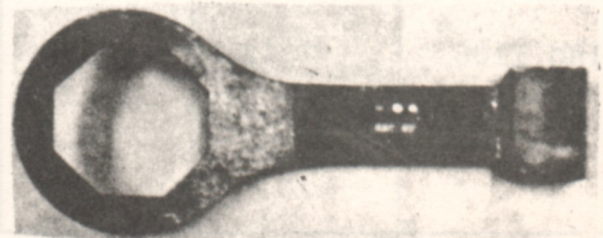

PART NO.	PRICE	AUSTIN AMERICA	MG 1100	SPRITE/ MIDGET	MGB	MGC	HEALEY 3000
18G 1112	\$ 3.50	*		*	*		
18G 1117	2.39				*	*	
18G 1118	9.08				*	*	
HAC 60	15.95		*	*	*	*	*
HAC 61 HAC 61A	22.95 6.75	*	*	*	*	*	
HAC 67	14.00	*	*	*	*	*	*

18G 1120 - Replacer Reverse Clutch Piston Seal *order*

To dismantle and re-assemble reverse clutch unit.

America Automatic

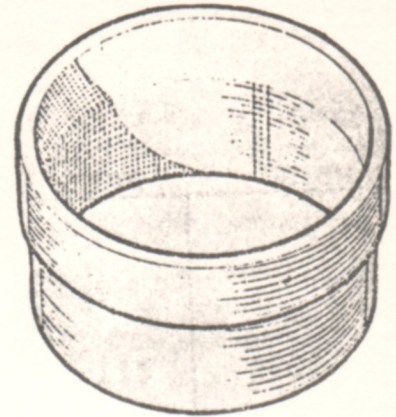

PART NO.	PRICE	AUSTIN AMERICA	MG 1100	SPRITE/ MIDGET	MGB	MGC	HEALEY 3000
18G 1120	\$16.10	*					