



TECHNICAL SERVICE BULLETIN

British Motor Holdings (U.S.A.) Inc.

734 GRAND AVENUE, RIDGEFIELD, NEW JERSEY 07657

February 29, 1968

TO ALL DISTRIBUTORS AND DEALERS

Re: Right Angled Speedometer Adaptor Failures

Repeated failures of the above have, in many instances, been caused by Washer-Adaptor to gearbox Part Number 3H 550 not being fitted when a new right angled drive adaptor is installed.

This causes an excessive end load and premature failure of the right angled drive pinion.

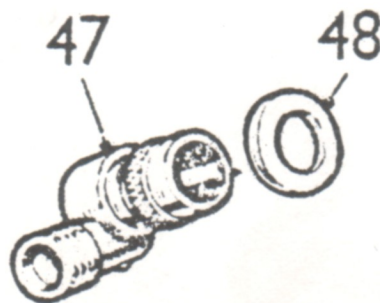

WASHER 3H 550